

HPGM Series HIGH Pressure Grinding Roll

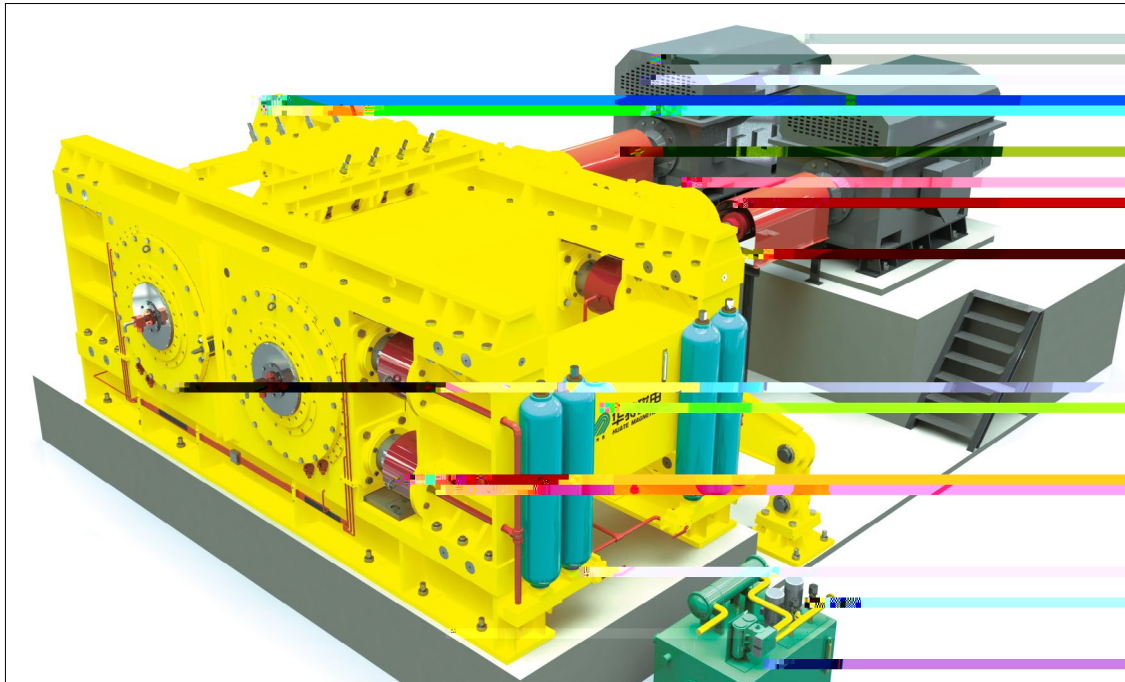

Working Principle

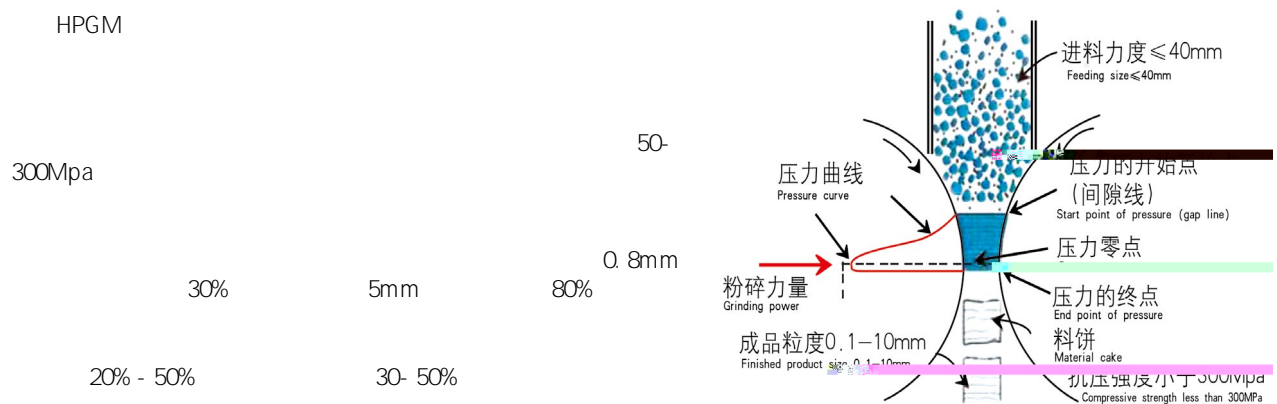

HPGM series high pressure grinding roll is a new type of energy- saving grinding equipment designed by the principle 6 other is a movable roll, which are both driven by a high- power motor. The materials are evenly fed from above the two rolls, and are continuously carried into the roll gap by the squeezing roll. After being subjected to a high pressure of 50- 300 MPa, the dense material cake is discharged from the machine. In the discharged material cake, in addition to a certain proportion of the qualified products, the internal structure of the particles of non- qualified products is filled with a large number of micro cracks due to high pressure extrusion, so that the material' s grind ability is greatly improved. For the materials after extrusion, after breaking up, classifying and screening, the fine materials of less than 0.8 mm can reach about 30%, and the materials of less than 5 mm can reach more than 80%. Therefore, in the further grinding process, the grinding energy consumption can be reduced to a large extent, so that the production capacity of the grinding equipment can be fully exerted, generally the ball mill system capacity can be increased by 20% -50%, and the total energy consumption can be reduced by 30% -50% or more.



Application Fields

There are many kinds of metal ore resources in China, but the qualities of most mineral varieties are poor, miscellaneous and fine. In order to solve the outstanding problems in the economic, technical and environmental protection aspects of mining development, domestic metal mining enterprises actively introduce, digest and absorb foreign new and efficient mining production equipment. In this market background, the HPGr is high-efficiency grinding equipment first researched and demonstrated, and begins to be used in domestic metal mining enterprises. It is also the mine production equipment most concerned by the domestic mining industry. It can be said that HPGr is widely used in domestic metal mines. The HPGr has been widely used home and abroad in the grinding in the cement industry, granulation in the chemical industry, and fine grinding of pellet to increase the specific surface area. It is used for the crushing of metal ore to achieve different purposes such as simplifying the crushing process, more crushing and less grinding, improving system productivity, improving grinding effect or separation indicators.

Practical Application Scope

- 1.
 - 2.
 - 3.
 - 4.
1. Medium, fine and ultrafine grinding of bulk materials.
 2. In the mineral processing industry, can be placed before the ball mill, as a pre-grinding equipment, or make up a combined grinding system with a ball mill.
 3. In the oxidized pellet industry, can replace the commonly used damp mill.
 4. In building materials, refractory materials and other industries, have been successfully applied in cement clinker, limestone, bauxite and other grinding.

Product Advantages:

- 1.
 - 2.
 - 3.
 - 4.
 - 5.
1. Constant pressure design ensures smooth pressure between rolls and ensures crushing effect.
 2. Automatic deviation correction, can quickly adjust the roll gap to ensure the smoothness of the equipment.
 3. The edge separation system reduces the effect of edge effects on the crushing effect.
 4. With cemented carbide studs, long service life, easy maintenance, and replaceable.
 5. The valve bank adopts imported components, and the hydraulic system has reasonable design and good reliability.



The difference between HPGr and roller crusher

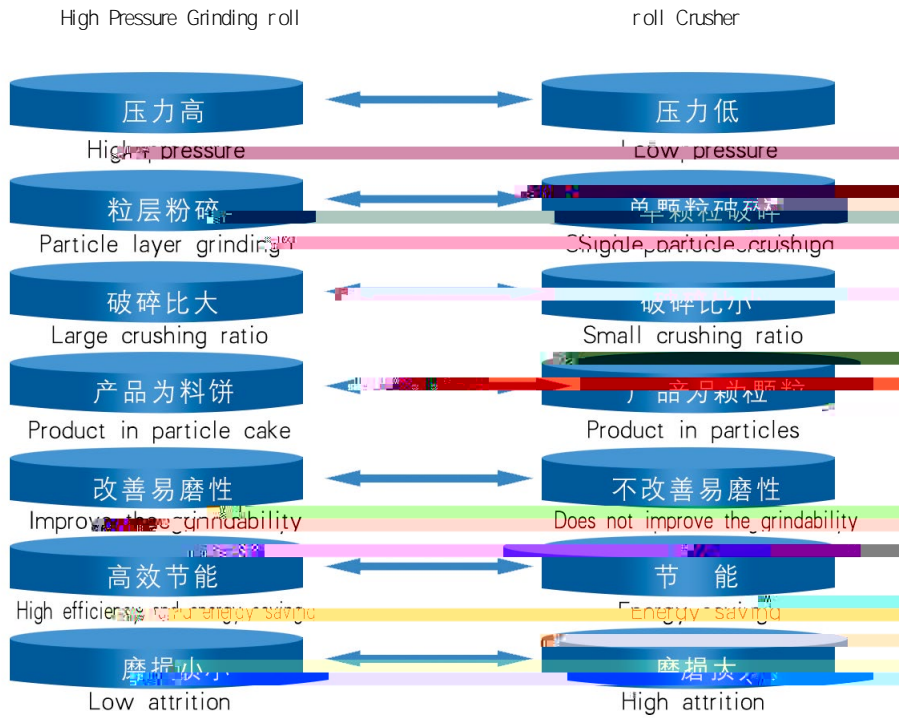

Structure of HPGr

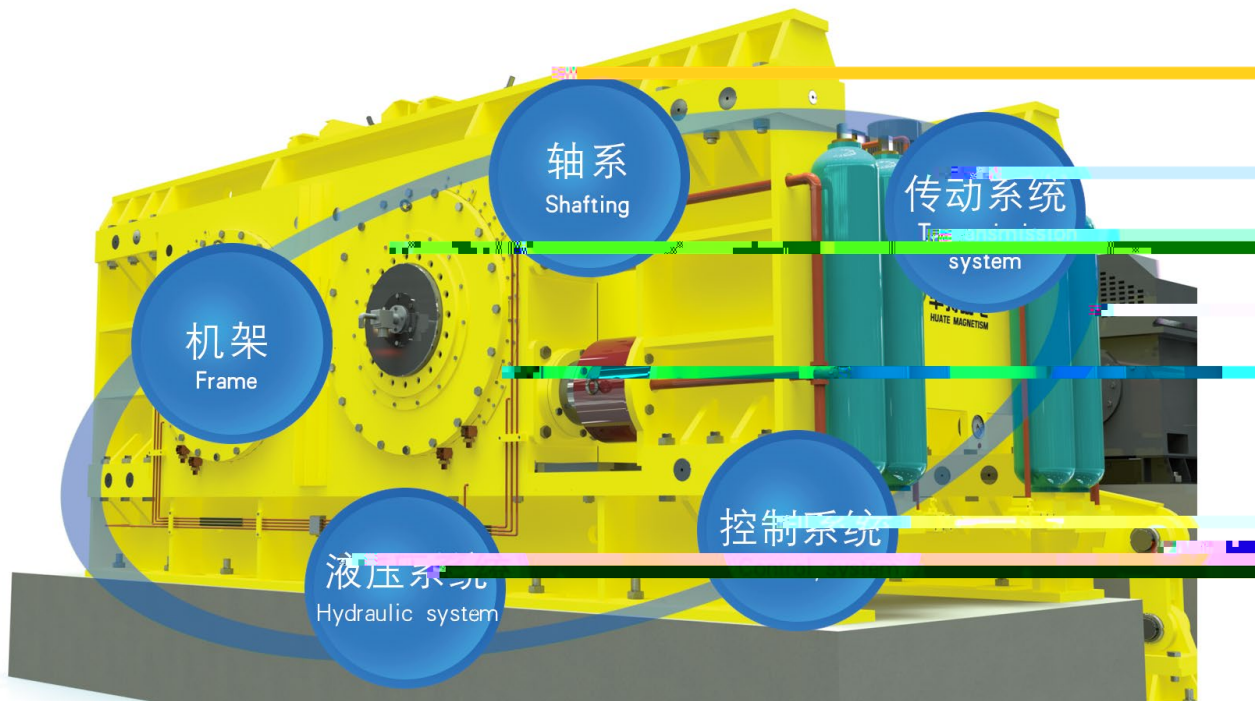

Product Parameters

| Model | roll diameter mm | roll width mm | Throughput capacity | Feed size | Machine weight t | Installed power |
|-----------|---------------------|------------------|------------------------|-----------|---------------------|-----------------|
| HPGM0630 | 600 | 300 | 25- 40 | 10- 30 | 6 | 74 |
| HPGM0850 | 800 | 500 | 50- 110 | 20- 35 | 25 | 150- 220 |
| HPGM1050 | 1000 | 500 | 90- 200 | 20- 35 | 52 | 260- 400 |
| HPGM1250 | 1200 | 500 | 170- 300 | 20- 35 | 75 | 500- 640 |
| HPGM1260 | 1200 | 600 | 200- 400 | 20- 35 | 78 | 600- 800 |
| HPGM1450 | 1400 | 500 | 200- 400 | 30- 40 | 168 | 600- 800 |
| HPGM1480 | 1400 | 800 | 270- 630 | 30- 40 | 172 | 800- 1260 |
| HPGM16100 | 1600 | 1000 | 470- 1000 | 30- 50 | 220 | 1400- 2000 |
| HPGM16120 | 1600 | 1200 | 570- 1120 | 30- 50 | 230 | 1600- 2240 |
| HPGM16140 | 1600 | 1400 | 700- 1250 | 30- 50 | 240 | 2000- 2500 |
| HPGM18100 | 1800 | 1000 | 540- 1120 | 30- 60 | 225 | 1600- 2240 |
| HPGM18160 | 1800 | 1600 | 840- 1600 | 30- 60 | 320 | 2500- 3200 |

() for reference only



Structural features of HPGr

It adopts high-quality hard alloy studs with high hardness and good wear resistance. The stud arrangement is designed by computer simulation, and the arrangement is reasonable, which can form a uniform material layer between the studs, effectively protecting the studs and roll surfaces, and improving the service life of squeezing roll. The studs are installed with imported special adhesives for easy replacement.

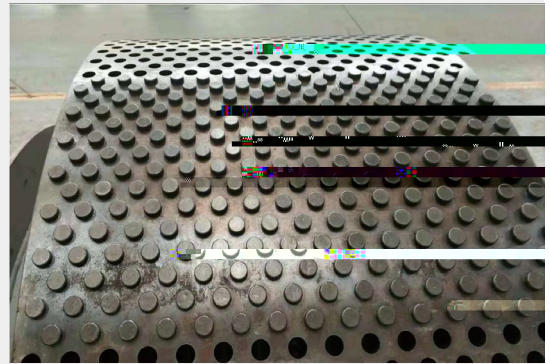

The main body of the squeezing roll is made of high-quality forged steel, and the roll bushing is forged with high-quality alloy steel. The main shaft and the rolls are made of different materials, which improves the toughness of the main shaft and the rigidity of the roll bushing. The service life of the shaft bushing is greatly improved. The replacement of the roll bushing is convenient.

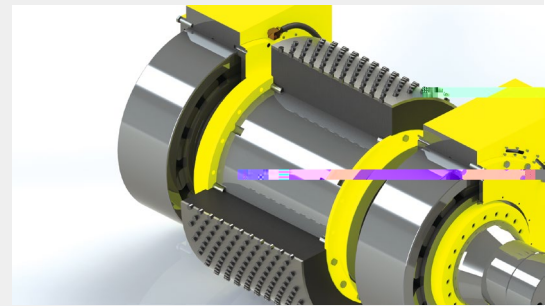

High-quality tapered hole bearings are adopted and high-pressure oil tank is preformed. The bearing can be easily dismounted through high-pressure oil pump, greatly reducing the difficulty of replacing the bearing and improving the maintenance efficiency.

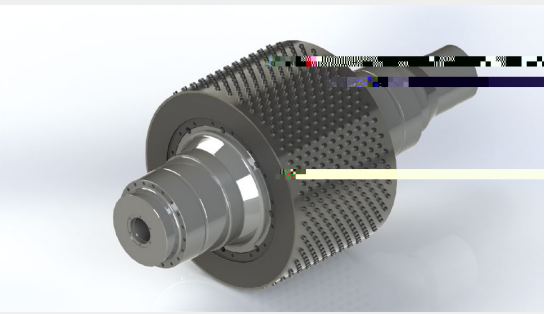

J V

The bearing seal adopts a variety of J-type plus V-type and labyrinth seals, and the combined sealing technology effectively ensures the sealing effect of the bearing.

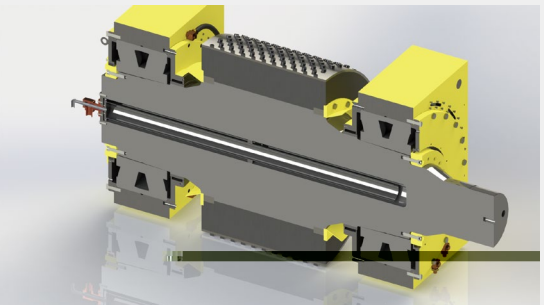

The frame is welded with high-quality carbon structural steel. The whole frame strength is three-dimensionally checked, with high strength and good reliability. The frame is processed by integral annealing and the frame deformation is small.

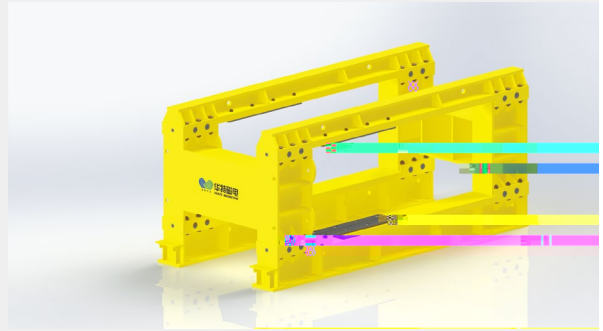

According to the crushing characteristics of different materials, the pressure parameters of the hydraulic system are optimized, and a special design is adopted especially for the crushing characteristics of metal minerals such as iron ore and manganese ore. The hydraulic valve group adopts imported famous brand products and is reliable and stable.

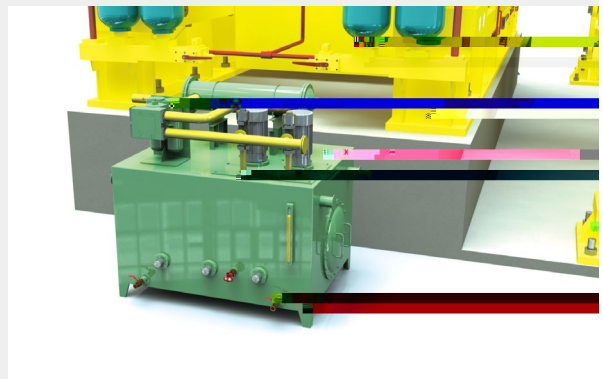

PLC

With Siemens PLC and full touch screen, and the overall control scheme, the whole machine can be unattended, and the pressure and various parameters can be easily modified to facilitate the crushing of different minerals. The whole machine adopts centralized lubrication system, which can adjust the lubrication amount and frequency with working conditions.



Iron Ore Beneficiation Flow

Crushing of Steel Slag

Crushing of Cement Clinker

Crushing & Grinding System of Iron Ore

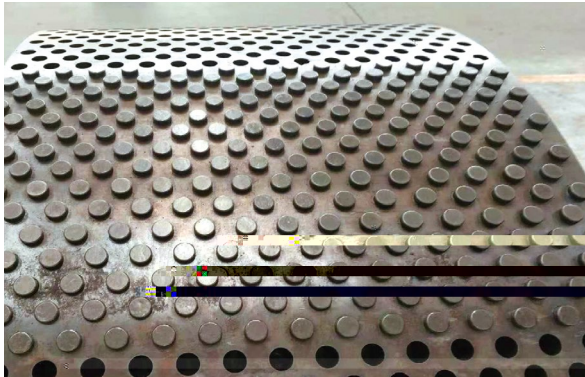
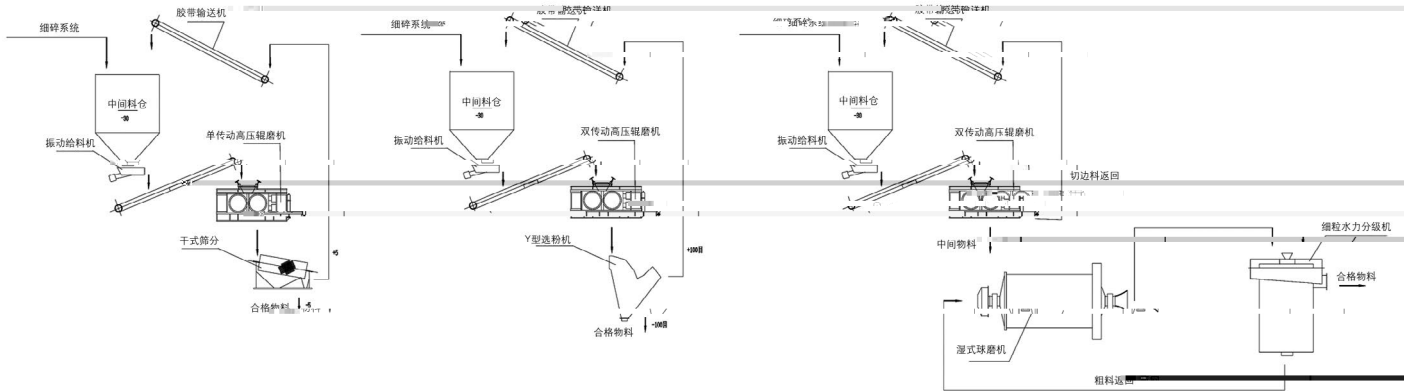

High Quality Wear-resistant roll Surface with Studs

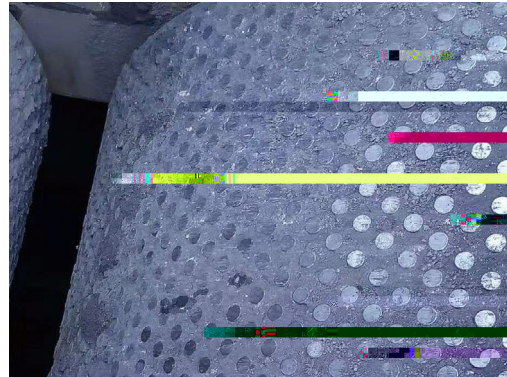

After the materials are extruded, a dense material layer is formed on the roll surface to protect the roll surface.



raw Material



Material Cake

